

SERAPID USA

PHANTOMPARK ELITE

Application Guidelines

Table of Contents

1. Overview	1
2. Responsibility and Code Compliance	1
3. Terms & Definitions	2
4. Subterranean Lift Applications.....	3
4.1. Areas of Use	3
4.2. Types of Use	3
5. Lift Types & Configurations	4
5.1. Electromechanical.....	4
5.2. Fixed vs Telescoping Canopy.....	4
5.2.1. Fixed Canopy	4
5.2.2. Telescoping Canopy	4
5.2.3. Synchronization.....	5
6. Lift Specification Considerations.....	5
7. Platform Attachments/Modifications.....	7
8. Lift Features	9
8.1. Standard Specifications.....	9
8.1.1. General for LL50R.....	9
8.1.2. General for VLB40	9
8.1.3. Mechanical Equipment	9
8.1.4. Standard Safety Devices.....	9
8.1.5. Controls.....	10
8.1.6. Deck Features.....	10
8.2. Optional Features	10
9. Installation Considerations	11
9.1. Pre-Planning.....	11
9.2. Subterranean Pit	11
10. Ship-Loose Electrical Components.....	17
11. Lift Safety Features (Non-electrical)	24
12. Start-up Testing.....	24

1. Overview

This application guideline is intended to provide information regarding the application of the Phantom Park Elite. This manual provides a guideline for the safety and installation considerations of a Phantom Park Elite. In addition, this guideline will offer an understanding of standard scope of supply and optional scope of supply.

Please, note that this document is intended to be used as a guideline only. The scope of supply can be customized if standard scope of supply does not fit an application. Please, contact American Custom Lifts for consultation with respect to application.

The purpose of this Application Guideline is to provide architects, contractors, designers, sellers, installers, owners, users and governing bodies with a source of information for consideration in design, application, and configuration criteria

This Application Guideline does not relate to:

- 1) Vehicle Maintenance Lifts as covered by ANSI/ALI ALCTV
- 2) Vehicle Elevators of any type as covered in ANSI/ASME A17.1
- 3) Surface-mounted parking lifts not placed within a subterranean pit/vault
- 4) Any lift designed to transport personnel
- 5) Lifts for handicapped access as described by ANSI/ASME A18

Please, note that the Serapid USA does not allow riding PhantomPark Elite by persons. If you choose to ride the lift, please, be aware that the risk of injury or death has been highly increased and you are doing it at your own risk.

2. Responsibility and Code Compliance

1. Parking Lifts are not vehicle elevators and do not meet the requirements of ASME A17.1 – Safety Code for Elevators and Escalators. At no time should these lifts be used to transport people.
2. Parking Lifts are not vehicle maintenance lifts and do not meet the requirements of ANSI/ALI ALCTV:2006 – Safety Requirements for Automotive Lifts. Under no circumstances should a person get under the lift without it being safely blocked open per the procedure in the Maintenance Manual.
3. Subterranean parking lifts designed to accommodate personal vehicles with normal axle loads and weight distributions for such. Standard parking lifts are not designed to withstand single axle loads greater than 4,000 lbs. at the front edge of the lift or a weight distribution that exceeds more than a 60/40 difference in total vehicle weight from front to back.
4. Each state, county, or municipality may have unique codes governing the installation and acceptance of residential parking lifts. Acquaint yourself with the permitting and/or licensing requirements (and expenses) of the local regulatory agencies.

5. Residential subterranean parking lifts should meet the applicable portions of the following nationally recognized safety standards:
 - a. ANSI Z535.4 Standard for Product Safety Signs & Labels
 - b. ASME A52 Structural Steel Standard
 - c. AWS B2.1/B2.1M Welding Qualification Standard
 - d. NFPA/NEC National Electric Code
 - e. OSHA 29CFR1910 General Industry Safety Regulations
 - f. ANSI MH29.1 Safety Requirements for Industrial Scissors Lifts
6. Unless specifically stated, subterranean parking lifts are not designed to raise loads placed on the canopy

3. Terms & Definitions

Approach Ramp: An access ramp used to load vehicles on/off of a platform, typically when the carriage comes to rest above the landing elevation.

Authorized Person: Trained or qualified personnel approved or assigned to perform a specific duty or duties.

Dynamic Capacity: The maximum load which the lift is designed to raise and lower.

Static Capacity: The maximum load which the lift may hold without moving.

Canopy: The upper platform assembly that travels above the uppermost landing when the lift is raised, and lowers into a recess/opening in the upper landing floor when lowered.

Carriage: The lower platform assembly that travels in the guide angles and carries the vehicle between landings.

Constant Pressure Push Button: A push button which, to activate, must remain pressed by the operator in order to perform a desired operation.

Controls: Any electrical device used to initiate or stop lift movement. Normally includes push button stations, control box, limit switches, interlocks, etc.

Control Voltage: The secondary voltage, which typically originates at a transformer and provides power to the control devices.

Rigid chain: Chain assembly that bends in one direction and locks as a rigid beam in the opposite direction. Used to replace hydraulic/pneumatic cylinders and cable systems. Pushes carriages upwards.

Enclosure (lift guarding): Structure surrounding the lift operating zone to prevent outside interference with its normal operation and to safe guard personnel.

Gate: A device that opens and closes manually or automatically to allow access to the lift operating zone. It is normally a swing, sliding, or vertical acting device constructed of rigid material.

Grade Level: Level at which vehicles enter and exit street level.

Landing: A permanent working surface at a fixed elevation used for loading and/or unloading a vehicle.

4. Subterranean Lift Applications

4.1. Areas of Use

- **Indoor/Garage** - Most residential vehicle parking applications are under the roof of an attached or detached garage and not exposed to the elements of weather.
- **Outdoor/Driveway** - Some residential vehicle parking applications are outdoor applications requiring a special lift design to accommodate the potential effects of wind, rain, snow & ice, etc.
- **Vehicle Vaults** - A vault application is one where no access to the lift is provided at the lower landing, accessibility to the lift and its components are from the upper landing only. This is common when the primary purpose of the subterranean lift is to provide security for the vehicle.
- **Two Landings** - Most common. Vertical transfer of vehicles is done between two fixed elevations/landings. This is normally between the garage and basement landings, but can also be between the garage and attic landings.
- **Three Landings** - Less common. Vertical transfer of vehicles is done between three fixed elevations/landings.

4.2. Types of Use

- **Vehicle Parking** - One of the primary motivations behind the specification and use of subterranean parking lifts is to take advantage of the vertical space available between upper and lower landings to provide additional parking space without expanding the square footage of the home/building to do so.
- **Vehicle Display** - One In addition to expanding vehicle parking space by storing vehicles below or above garage level, many owners choose to raise or lower their prized possessions into enhanced viewing space (special lighting, background, etc.).
- **Vehicle Transport/Motor Court** - When the architectural plan allows, expanded square footage for parking can be provided at elevations below or above the main garage level, and the subterranean lift is used to transport vehicles between elevations where they are driven off the lift and parked adjacent to the lift operating zone.

- **Vehicle Security** - One primary motivation for installing a subterranean parking lift is to be able to provide a safe and secure parking location below grade for prized vehicles – to better protect them against theft or vandalism, and to prevent unauthorized access to them (as in the case of time-shared properties, etc.).

5. Lift Types & Configurations

5.1. Electromechanical

Electromechanical lift is typically powered by two AC motors, however, please note that some lifts are custom. The motor(s) drive four rigid chains that allow lifting of load. The chains lock in one direction of bending and bend in another direction, which allows them to behave like rigid beams when pushing the load in the upwards direction. There are no hydraulic or pneumatic components in the electromechanical system. This allows the system to have the following advantages over other systems:

1. Quiet and smooth operation
2. Low maintenance cost and simple maintenance activities
3. Self-locking at any elevation
4. Easy and short start-up activities
5. Higher reliability for less cost
6. Synchronization for less cost and fewer components
7. Variable speed of lift and programmability
8. No oil spills due to lack of hydraulics or possibility of leaking onto vehicles
9. Very limited amount of field welds
10. No mechanical room required and expense of building square footage
11. Higher speed of operation

The disadvantage of electromechanical system is that it features higher initial investment. However, higher initial investment can be offset with lower cost of ownership.

5.2. Fixed vs Telescoping Canopy

5.2.1. Fixed Canopy

Rigid stanchions are used when the overhead clearance at the upper level (typically the garage ceiling) is equal to, or greater than, the vertical travel distance between the upper and lower landings. Canopy stanchions are fixed height and field-attached between the carriage and canopy.

5.2.2. Telescoping Canopy

Telescoping canopy is specified when the overhead clearance at the upper level (typically the garage ceiling) is less than the vertical travel distance between the upper and lower landings. Carriage features stationary posts of shorter height that pick-up canopy as lift moves upwards. The canopy rests in a foundation recess at the upper slab. Therefore, the contractor needs to put in a lip and reinforce it with the angle at the upper slab. The lip (recess) would be only on the length of the pit opening (both sides).

5.2.3. Synchronization

The lift is synchronized by interconnecting the drive train by series of drive shafts. This way, the motors drive all four chain systems, which, in return, push the structural components of the lift.

6. Lift Specification Considerations

- **Vertical Travel** - The difference in elevation between the top surface of the carriage at the bottommost level and the top surface of the carriage at the uppermost level – regardless of whether the unit is in pit or surface mounted.
- **Floor-to-Floor Distance** - The distance from one finished floor level to the next finished floor level.
- **Capacity, Size and Type of load** – Capacity does not only refer to the weight of the load but also the physical size and configuration of the load. Types of loads are typically: cars, trucks, trailers, motorcycles, powered carts, etc. The platform should be sized to handle the largest loads with adequate clearances for entering and leaving the carriage. The capacity should also take in consideration any dead (non-moving) weight such as material added to the parking decks (concrete, brick pavers, etc.), and the weight of any equipment used for loading and unloading objects.
- **Traffic Pattern** - The traffic pattern of vehicles entering and exiting the lift is critical to determining:
 1. Necessary clearances between canopy stanchions
 2. The need for a pit (for off-loading at the lower level)
 3. The design and layout of lift guarding (doors, gates, enclosures, barriers, etc.)
- **Axle loads** - Consideration must be given to a vehicle's axle weight as it rolls across the edge of the platform when entering & exiting the lift. Standard units assume that maximum disparity in axle weights between front and rear axles is a 60/40 split in total vehicle weight. The manufacturer must be made aware of any axle weights that exceed this.
- **Electrical Considerations** - The following should be considered:
 1. There should be two wall penetrations (by others) in the machinery pit:
 - a. High Voltage-2" Conduit (QTY .1)
 - b. Low Voltage-2" Conduit (QTY.1)
 2. Severe operating conditions, such as outdoor applications, often require special electrical components.
 3. The maximum current draw should be approximately 26A for LL50R solution and 15A for VLB40 solution
 4. The motor control center panel is fused at 60A for LL50R solution and 50A for VLB40 solution

5. There is field wiring to be done to connect all the peripheral electrical signaling devices to the main motor control panel.
- **Operating Considerations** - The following should be considered:
 1. Optional vehicle location sensors/devices are available to ensure that the entire vehicle is within the area of the platform prior to raising or lowering the lift.
 2. Optional sensors are available to ensure that a vehicle is not parked on the top canopy prior to the lift being raised.
 3. Optional lift finishes are available – to better combat the effects of severe operating conditions such as salt water, ice/snow, etc.
 4. Optional power unit configurations are available to increase the speed of the lift – should that be a major consideration.
 5. Additional security against unauthorized use and operation of the lift.
 - **Guarding the Lift Operating Zone** - Personnel safety during lift operation is of utmost importance, and some safety features are sold as standard with every lift. Additional, optional, guards, safeties, and restraints are available to prevent inadvertent contact with a moving lift – on both the operating level, and the level that is outside the operator’s direct line of sight. **NOTE** – *Any alterations to safety features should insure all features are maintained*
 - **Security Cameras (standard)** - Security cameras are mounted in the lift operating zone at the level not occupied by the operator. These cameras allow the operator to view the portion of the lift zone that is outside his direct line of sight by watching the monitor mounted adjacent to the pushbutton station.
NOTE – cameras are not required in a vault application with no access at lower level.
 - **Audible Alarm (standard)** - An adjustable audible alarm that sounds off any time the lift is moving, or is left in any position other than the fully raised or fully lowered position, to warn people in the area of lift movement.
 - **Emergency Stop Button (standard)** - E-Stop stations are mounted in the lift operating zone and on the motor control center. Pressing this large, red “panic” button removes all power to the lift controls and renders the lift inoperable until the button is manually reset.
 - **Motion Sensors (standard)** - These sensors are mounted in the lift operating zone at the level not occupied by the operator. Any motion that is detected while the lift is moving automatically disables the operator pushbutton station and stops the lift.
 - **Doors** - It is common to have doors for access to the lift operating zone at both the operating level to and the non-operating level to prevent incidental contact with the lift. It is required that the status of these doors be monitored, and/or interlocked to prevent entry ingress/egress while the lift is moving.
 - **Gates** - The manufacturer can also supply commercial gates, typically at the storage landing, to prevent personnel ingress/egress during lift operation. Gates can be designed to swing, slide, or

roll up – depending on the application & architectural features of the floor plan. It is recommended that the status of all gates be monitored, and/or interlocked.

- **Enclosures** - In addition to conventional walls which can be constructed around the lift operating zone to prevent access to the lift, the manufacturer can supply commercial/industrial (typically expanded metal) enclosures as personnel barriers.
- **Status Switches** - Door status switches are recommended for all doors leading into the lift operating zone to prevent operation of the lift if a door is in the “open” status. These switches come in a variety of designs, depending on the style door that they are mounted to.
- **Interlocks** - Door interlocks are also recommended for all doors leading into the lift operating zone to temporarily and automatically place the door into “lock” condition whenever the lift carriage is moving. Interlocks also come in different designs, including some that are available as a combination status switch and interlock.
- **Photo Eye Sensors** - Photo eye sensors can be placed at strategic points around the unprotected/unguarded edges of the lift carriage to detect any interference with people or objects that break the photo eye path. If this path is broken, the lift will immediately be rendered inoperable until the interference is removed.

7. Platform Attachments/Modifications

Accommodations can usually be made to enhance the performance or appearance of the lift by adding optional features to the carriage and/or canopy. In most cases, any additional weight that these features may add to the overall lifting requirement has been taken into account in the rated lifting capacity. Consult the manufacturer to inquire as to whether or not these may cause the lifting capacity to be de-rated by some amount.

- **Platform “Lip”** - A permanently welded raised lip or flange around the perimeter of the canopy platform to assist in holding/containing loose material added for aesthetics, such as concrete, dirt/sod, gravel, brick pavers, ceramic tile, etc.
- **Perimeter Overlap – Canopy Deck** - In wet climates, there may be a concern about water/snow dripping off of vehicles parked on the canopy down to the lower landing. In this case, the overlap is provided between the platform and the upper level. It is recommended to add a gutter to the outer edges of the pit to collect liquid.
- **Platform “Skin”** - Sometimes sheets of material are attached to the either/both deck surfaces for aesthetics or corrosion/wear resistance, such as stainless steel, aluminum, and wood laminate.
- **Bump bars** – Bump bars offer inexpensive solution to ensure that the vehicle is parked within the right location on the platform. The chosen location will ensure that the vehicle ends are not

going to be damaged when the vehicle is raised or lowered. The bump bars are attached to the carriage.

- **Maintenance Access Hatch – Canopy Deck** - A maintenance hatch comes standard in the lower carriage deck to be able to access the underside of the lift when the lift is fully lowered. If access to this hatch is limited or removed – as is the case with a vault application, where no access to the lift is provided at the lower level – then an additional hatch is placed in the upper canopy deck to be able to access the lower deck from the upper deck/upper landing.

8. Lift Features

8.1. Standard Specifications

The following represent the features of a “standard” lift:

8.1.1. General for LL50R

- Travel: Std. Maximum: 120”
- Dynamic Load Capacity: 7,000 lbs
- Static Load Capacity: 14,000 lbs
- Raising/lowering speed: 12 feet per minute
- Pit depth: 30”
- Two stops
- Four open sides
- Two year limited warranty on parts
- Ten year warranty on structure

8.1.2. General for VLB40

- Travel: Std >120”
- Dynamic Load Capacity: 7,000 lbs
- Static Load Capacity: 14,000 lbs
- Raising/lowering speed: 12 feet per minute
- Pit depth: 30”
- Two stops
- Four open sides
- Two year limited warranty on parts
- Ten year warranty on structure

8.1.3. Mechanical Equipment

- Upper Canopy deck
- Lower Carriage deck
- (4) Stanchions
- (4) VLB40 or (4) LL50R Chain Systems
- 230VAC, 60Hz, 26 amp single phase power supply

8.1.4. Standard Safety Devices

- Security key switch station
- Digital security keypad
- Emergency stop station
- Lift-in-motion audible alarm
- Motion detection system
- Camera system
- Operator pushbutton
- Beveled toe guard on top canopy

8.1.5. Controls

- Programmable Logic Controller
- Self-diagnostic system with digital display

8.1.6. Deck Features

- Larger sizes (108"W x 216"L is standard size)

8.2. Optional Features

- Higher speed
- Battery operated
- Custom platform sizes
- Higher dynamic capacity
- Ultrasonic position indicator with lights
- Command Center
- Biometric (fingerprint) security scanner
- Door status switch
- Door interlock kit
- Special paint colors
- Stainless steel deck plate
- Photo-eye interference detection
- Vehicle present photo-eye sensor
- Vehicle present advanced technology sensor
- Lift-in-motion flashing light
- Sensing edge for interference detection
- Pressure-sensing floor mat

9. Installation Considerations

9.1. Pre-Planning

Whenever possible, make a pre-installation visit or call someone at the site. Installers must be familiar with the proper installation procedures of this equipment. Some concerns are listed below, though listing every affecting contingency is impossible. It is the installer's responsibility to check the site for problems and work out solutions with the appropriate people. Some of the areas of concern are:

1. Is the site accessible to large delivery & cartage vehicles?
2. Can the lift components get through the existing doorways & floor openings?
3. How will the unit be raised, set into position, and accessed?
4. Can a chain fall be hooked to an available overhead support?
5. Is there a forklift or other cartage equipment available?
6. Is there adequate building structure to support vertical guides?
7. Look for problem areas such as bracing and overhead interference with ceilings, joists, pipes, etc.

9.2. Subterranean Pit

Because the lift guides attach to the subterranean pit walls, it is critical that the pit be correct per manufacturer's recommendations and consider the following:

1. Pit floor must be flat and level within 1/2" (plus or minus 1/4").
2. Pit walls must be straight and plumb within 1/4".
3. Make sure pit is properly squared and vertically aligned with the opening in the garage floor to ensure clearances of at least 3/4" between outside perimeter of lift and inside perimeter of floor opening - follow manufacturer's recommendations as shown on the pit drawing.
4. Provide adequate drainage to pit area to prevent pit from filling with water.
5. Run a couple of 2" schedule 40 pipe, with long radius sweep elbows, to provide a pipe chase for power and control conduits. One pipe for power (high voltage) and another for control (low voltage).
6. The pit floor should have sufficient strength to withstand the loads as shown on the manufacturer's approval drawing.
7. The total pit depth should be such that it will allow shimming of the lift landing legs to bring the carriage top surface flush with the lower landing.

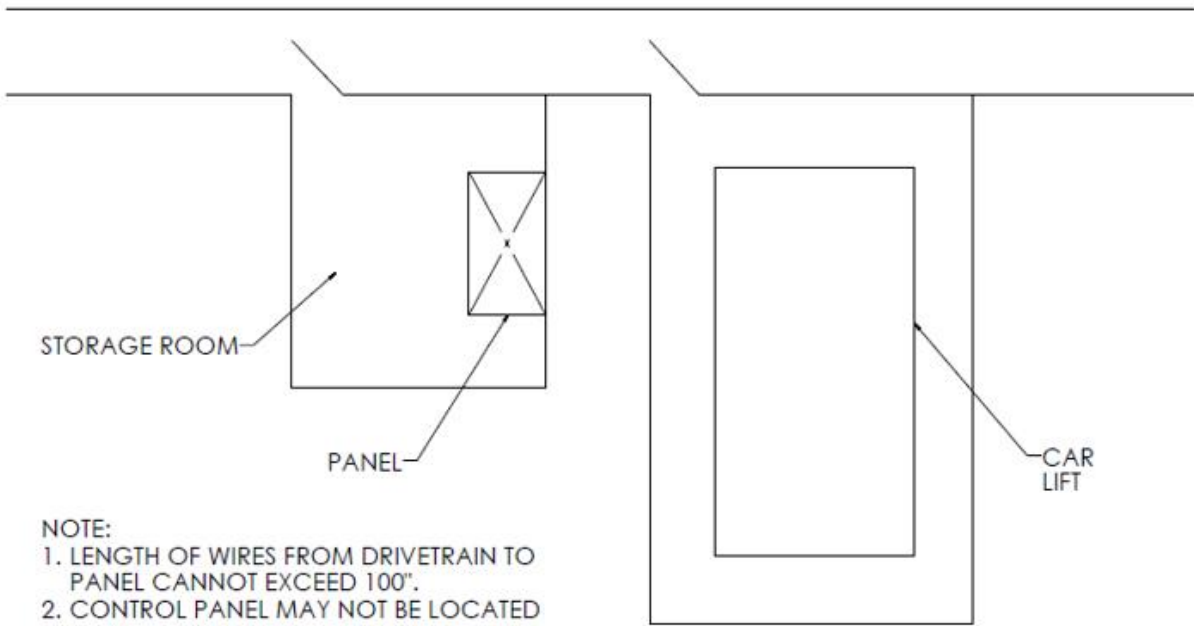

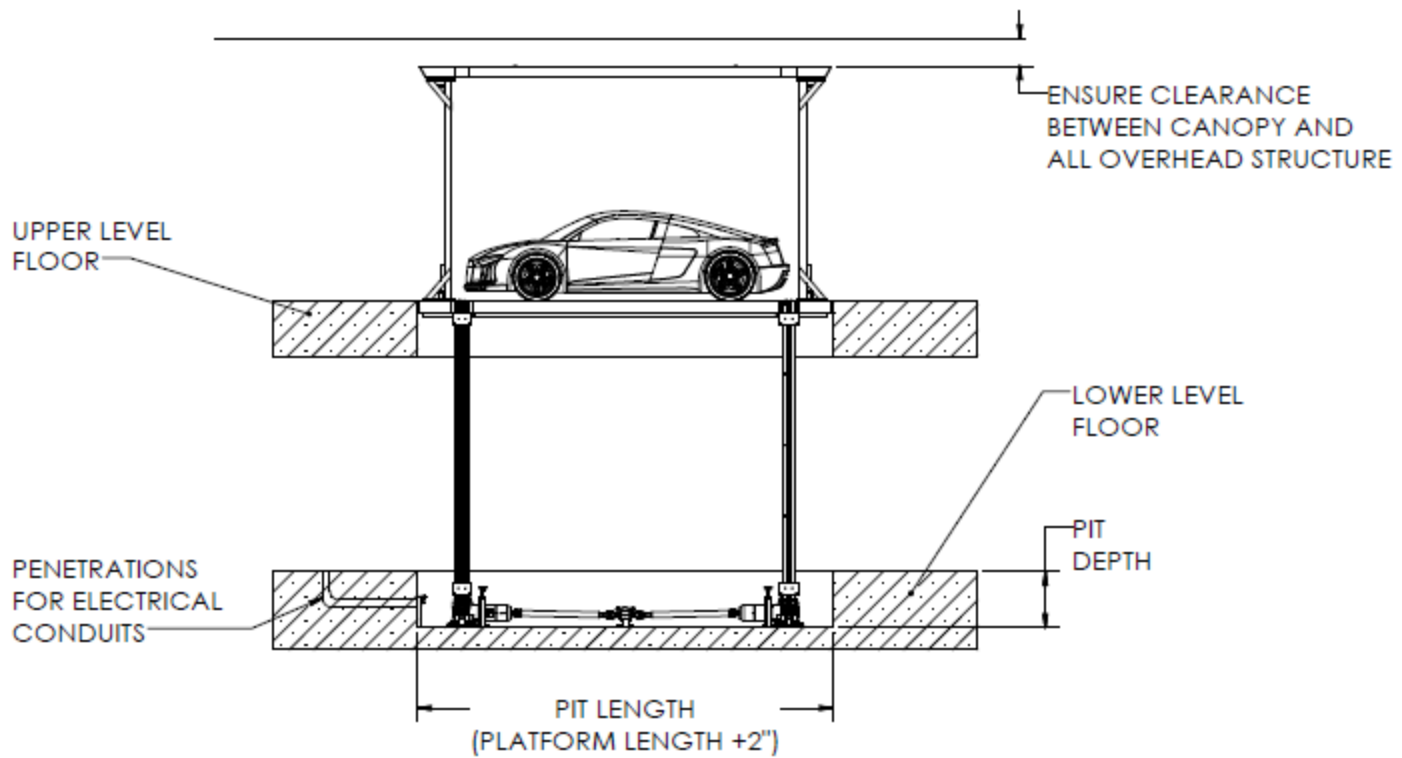

NOTES:

1. It is advised to place two separate (2" conduit) penetrations for electrical conduits. Both penetrations can be of the same size. One penetration for power conduits (high voltage) and one for control conduits (low voltage)
2. It is recommended to locate exit of electrical penetration a few inches off the pit floor to ensure that it will not flood with liquid and to ensure that the exit will not be blocked by lower platform when lift is in fully retracted position

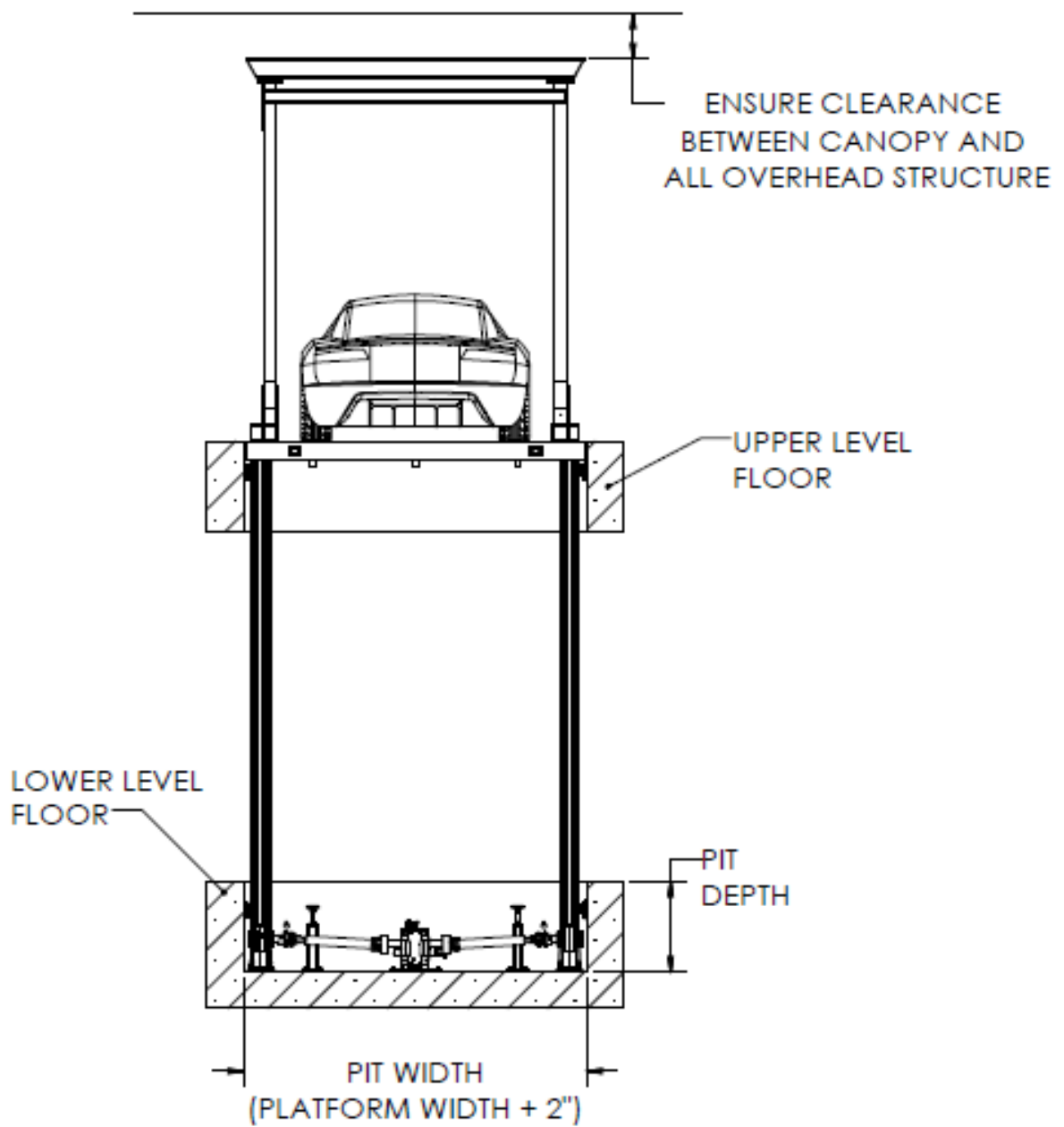

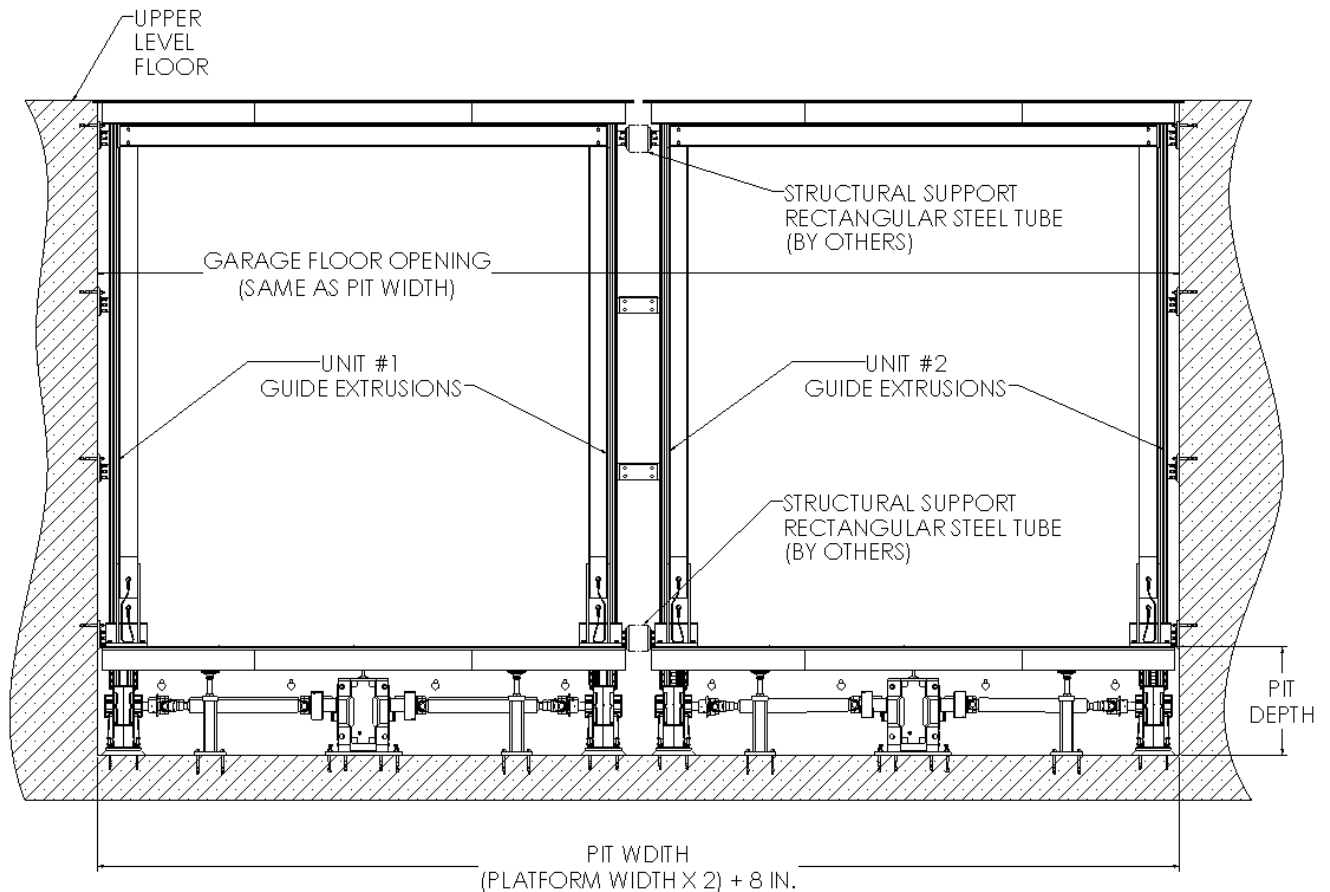

- **Lift Operating Zone** - Care must be taken to evaluate all architectural features which could impact the installation and performance of the subterranean lift:
 - Verify the construction and integrity of building columns, joists, walls, or mezzanines that will be used to help support the four (4) guide extrusion assemblies (per lift)
 - Be sure to take into consideration any other obstructions (pipes, ductwork, ceiling joists/beams, etc.) that may be located around the lift.

- **Vertical Guide Extrusion Assemblies (VLB applications only)**- Because the 4-post subterranean lift is a platform lift (i.e. not a scissors lift), it achieves its lateral stability from the vertical guide extrusion assemblies that are attached to the building structure at each of the four corners of the lift. There will be two anchoring points (one on the upper and lower slab of the machinery pit). The columns will be supported using an intermediate guide for VLB applications. In order for the lift to perform as designed, it is critical that these guide extrusion assemblies be installed exactly to manufacturer's specifications, and adhere to the following basic requirements:
 - When anchoring the corner vertical guide extrusion assemblies to walls, you must be sure that the walls can support the reaction loads imparted on them
 - Ensure that there are two walls in close proximity to the corner vertical guide extrusion assemblies, for anchoring. The anchoring walls should be along the longitudinal direction of the lift
 - Corner vertical guide extrusion assemblies must be straight and plumb within 1/8" for the lift to operate properly.

- Do not modify the corner vertical guide extrusion assemblies – or any other component of the lift – without expressed written consent from American Custom Lifts.

Note: In some areas, seismic calculations may also be required prior to the installation of a subterranean parking lift. Check your local and state requirements for criteria regarding the extent of these calculations and the qualifications required by the engineer who performs them.

- **Utility Room/Area** - It is not necessary to have a utility room/area for PhantomPark Elite. The main electrical control center (electrical panel) can be located in the same room as the lift. Customers are, also, welcome to locate main electrical control center in the separate room. However, considerations must be considered for routing electrical conduits from remote room to the lift room.

10. Ship-Loose Electrical Components

Motion detector (QTY. 2)

Sensors are mounted above and just outside each unprotected edge of the lift platform to detect motion in the lift operating zone outside the line of sight of the operator. If any motion is detected, an electrical contact opens, in the control circuit, and the operator will not be able to operate the lift until the timer (adjustable) resets



Dimensions: 3-1/2" dia.

Location:

Lift operating zone, out of line of sight of operator
(typ. lower level)

Mounting: ceiling mount

Voltage: 24 VDC

Materials: jigsaw, pencil, screwdriver

Keypad station (QTY. 1)

This station serves as the secondary security & authorization device and requires a code to be entered to enable the controls of the lift. This station is wired in the control voltage circuit to prevent unauthorized operation of the lift. Authorized code times out after certain period of inactivity and must be re-entered. "ON/OFF" keyed switch has to be turned to "ON" position before entering the code.



Dimensions: 3" x 5"

Location:

Secure location, preferably near lift operating zone

Mounting: wall mounted

Voltage: 24 VDC

Materials: drill, sheetrock screw anchors

Wireless security camera (QTY. 2) and monitor (QTY. 1)

Two wireless, digital and weatherproof cameras (IP 66) are mounted at the lower level to give the operator a complete view of the lift operating zone which is outside his/her line of sight. One monitor is located at the operator station to be able to watch all zones during lift operation



Dimensions: 7-3/4" x 4-3/4" (monitor)

Location:

Cameras – lift operating zone (typ. lower level)

Monitor – adjacent to operator P/B station

Mounting:

Cameras – wall mounted

Monitor – tabletop, wall, or under-cabinet

Power:

Cameras – 100-240 VAC/0.18 A (wall outlet)

Monitor – 100-240 VAC/0.18 A (wall outlet)

Materials: drill, sheetrock screw anchors (cameras)

Electromagnetic door lock kit (QTY. 2)

Electromagnetic door lock kit consists of electromagnetic door lock and a proximity (non-contact) switch. The electromagnetic door lock uses magnetism to lock the door when lift is in use. The proximity switch tells control center that the door is closed or opened



Location: top of door or bottom of doorframe

Mounting:

Lock – screws into door or doorframe

Switch – integrated into a lock

Striker – screws into door or doorframe

Power: 24 VDC

Materials: drill, screws, screw anchors

Vehicle presence sensor (QTY. 3)

Vehicle presence sensor is mandatory for indoor installations. Vehicle presence sensor ensures that the vehicle, parked on top of canopy, is not crushed against the ceiling of the garage. Three sensors are mounted on the garage level and check for presence of an object (primarily vehicle) in three different spots along the length of the lift. The sensor emits the beam and receives it after it is reflected by a reflector. The reflector is to be mounted opposite of the sensor. If the beam is broken, then there is an

object on the platform and the lift does not move. Lift can be moved once the object is removed and sensor can emit/receive signal



Location:

Garage level, three equally spaced locations along length of lift

Mounting:

Sensor (emitter and receiver)– bracket mounted to the floor/wall

Power: 24 VDC

Materials: drill, concrete screws and wrench

Operator up/down pushbutton station (QTY. 1)

This station provides the primary controls of raising and lowering the lift and should be located adjacent to the lift operating zone. It is best to locate it in the vicinity of the security keypad station. The buttons must be pressed and held by the operator during all lift movements. This has to be done to stop the lift in the event of emergency by releasing the button. In addition, the security camera monitor has to be observed at all times while the button is pressed



Dimensions: 3" x 5"

Location:

Adjacent to lift operating zone, in line of sight with lift

Mounting: wall mounted – 1 gang plate

Voltage: 24 VDC

Materials: drill, sheetrock screw anchors

Emergency stop station (QTY. 1)

The emergency stop “panic” button which, when pushed, removes electrical power from the control circuit and immediately stops lift movement. E-stop station should be located near the lift controls (up/down pushbuttons). E-stop button must be manually reset, by following directions on the button, to continue operation



Dimensions: 3” x 5”

Location: adjacent to the lift controls

Mounting: wall mounted – 1 gang plate

Voltage: 24 VDC

Materials: drill, sheetrock screw anchors

Authentication keyed switch station (QTY. 1)

This station is the primary security device in the control circuit and requires a physical key to turn the control system to “ON”. This station is wired in the control voltage circuit to prevent unauthorized operation of the lift. “ON/OFF” keyed switch has to be turned to “ON” position before entering the code into the keypad



Dimensions: 3” x 5”

Location:

Secure location, preferably near lift operating zone

Mounting: wall mounted – 1 gang plate

Voltage: 24 VDC

Materials: drill, sheetrock screw anchors

Audible alarm (QTY. 1)

An audible alarm will activate any time the “UP” or “DOWN” pushbutton is pressed to notify anyone in the area that the lift is being operated. It will continue to signal alarm until lift reaches desired position. The alarm will also sound if there is an error or fault in the system. The volume is adjustable



Dimensions: 72 mm in diameter

Location:

Adjacent to lift operating zone, out of line of sight of operator (typ. lower level)

Mounting: wall mounted – 1 gang plate

Voltage: 24 VDC

Materials: 1 blank gang plate, 22.5 mm hole

Emergency egress pushbutton station (QTY. 2)

These buttons are provided in case lift room or area needs to be escaped from, in the case of emergency (fire, flood and etc.). These buttons are meant to be located on the upper and lower levels of the lift (or upper level only if there is no access on lower level). These buttons need to be located on the inside of the lift room, rather than outside, as they are meant as a provision for escaping from the room



Dimensions: 3" x 5"

Location:

On upper and lower levels (upper level only, if no access at lower level). To be mounted on the inside of the room, adjacent to a door

Mounting: wall mounted – 1 gang plate

Voltage: 24 VDC

Materials: drill, sheetrock screw anchors

Optional Peripheral Equipment

Indoor command center (QTY. 1)

The command center unites keypad, pushbuttons for raising/lowering the lift, e-stop station and security camera monitor in one package. The command center offers convenience of centralized controls and aesthetically pleasing package. The indoor command center is not weatherproof. It features brushed stainless steel fascia or steel fascia powder coated to your color, and the main body of command center is recessed into a wall



Dimensions:

Fascia – 1/8" Thick x 16-1/4" Wide x 16-15/16" Tall

Box – 3-3/4" Deep x 14-1/4" Wide x 14-15/16" Tall

Location:

Indoors, adjacent to the lift room or in close proximity to the lift. Can be out of sight of the lift

Mounting:

Recessed wall mounted, anchored inside wall pocket

Voltage: 24 VDC

Materials: wood screws

Outdoor command center (QTY. 1)

The command center unites keypad, pushbuttons for raising/lowering the lift, e-stop station and security camera monitor in one package. The command center offers convenience of centralized controls and aesthetically pleasing package. The outdoor command center is weatherproof. It features stainless steel fascia and the main body of command center is recessed into a wall



Dimensions:

Fascia – 1/8” Thick x 16” Wide x 18-1/8” Tall

Box – 6” Deep x 14” Wide x 16-1/8” Tall

Location:

Outdoors, can be out of sight of the lift

Mounting:

Recessed wall mounted, anchored inside wall pocket

Voltage: 24 VDC

Materials: sealant, concrete screws

Electrical Installation Notes

- **Code Compliance** - All electrical work must meet the requirements of all state and local codes. Make sure that only qualified electricians perform all wiring.
- **Control Panel** - The control panel is shipped loose with all internal components pre-wired to terminal strip(s) and all control logic managed by programmable relays.
- **Bi-Level Operation** - If the lift is to be operated from both levels, a duplicate set of electrical control and safety devices must be purchased – to ensure safeguarding of the landing that is out of the line of sight of the operator.
- **Bypassing Devices** - **NEVER** bypass any safety sensor or device.

11. Lift Safety Features (Non-electrical)

- **18-3/4" Refuge Space Beneath Lift** - A mechanical feature unique to the 4-Post style lifts is a completely clear 18-3/4" crawl space beneath the entire lower deck for personnel safety during operation and maintenance.
- **Beveled Toes Guard Protection** - A mechanical feature added to the perimeter of the lift canopy intended to push away, rather than pinch, a shoe which is overhanging a landing by up to 4 inches.
- **Maintenance Chocks** – A mechanical lockout device that is used in case of maintenance of lift(s). The lift is raised to its maintenance position (all the way up) and maintenance chocks are utilized to prevent lift from lowering under gravity when drive components require replacement or service. Maintenance chocks must be set back into its original position before lowering the lift to its safe position (all the way down).

12. Start-up Testing

Typical Start-up Procedure:

1. Close all doors/gates leading into the lift operating zone.
2. Run the empty carriage to the upper landing and set upper limit switches. Ensure to have a spotter at all times to avoid collisions or running out of stroke.
3. Run the empty carriage to the lower landing and set lower limit switches. Ensure to have a spotter at all times to avoid collisions or running out of stroke.
4. Run the empty carriage to the upper landing.
5. Check that doors at all levels will not open while the lift is running.
6. Check to ensure the lift will not operate if any door is open.
7. Place a load on the carriage and lower the carriage to the lower landing, then back up again. The carriage should stop at the upper elevation even with the landing – whether loaded or unloaded.
8. Check to ensure the lift operates at the rated speed.
9. The parking lift should function smoothly and relatively quietly. If the lift does not function as stated, or does not pass these tests, consult the manufacturer before putting the lift into service.
10. Check that each of the safety devices delivered with the lift, and described herein, will stop the moving carriage if activated.
11. To ensure the rigid chain does not run out of stroke, ensure the red roller inside the housing cannot be seen outside of the housing. Check sight of red roller at housing exit near maximum stroke.