



# AMERICAN CUSTOM LIFTS

888-711-5438 | 619-286-543

www.aclifts.com | Fax: 619-330-2111

Email: sales@aclifts.com

720 N. Norma Street Suite D | Ridgcrest, CA  
93555



## WAS112E-24 SITE SPECIFICATIONS

Model No.	Figure	WAS112E-24
Category	---	Two Post
Lifting Capacity	---	11,000 lbs.
Overall Height	A	165.50"
Overall Width	B	138.50"
Rise Height	C	73.75"
Floor to Shut Off Height	D	159.00"
Drive Thru Clearance	E	96.00"
Arm Configuration	---	All-Symmetric
Front Arm Reach	F	48.75"
Rear Arm Reach	G	62.00"
Lifting Pad Height	H	4.75"
Width Inside Columns	I	115.00"
First Lock Height	---	16.50"
Locking Increments	---	4.00"
Speed of Rise	---	55 Seconds
Motor	---	2 HP
Voltage	---	208/230 Single Phase
Amps	---	30
Ceiling Height Requirement	---	169.50"
Floor Installation Requirement	---	Concrete, 3,000 PSI, 4" Thick, Steel Reinforced

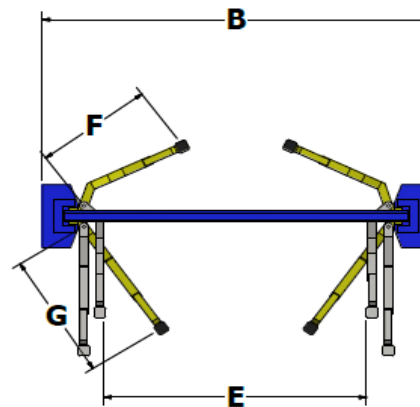
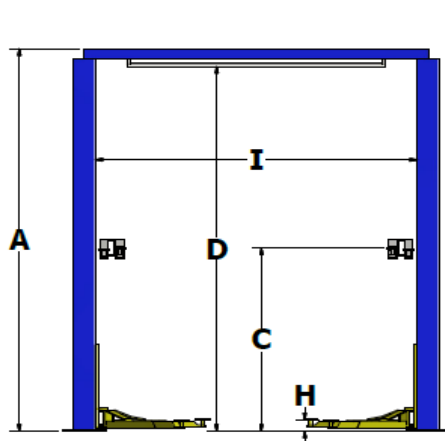

American Custom Lifts, Inc. reserves the right to make changes to specifications without notice and without making changes retroactive. Unloading, installation and oil not included.

[WWW.ACLIFTS.COM](http://WWW.ACLIFTS.COM)